

# JPL Series Air Atomizing Nozzles





# JPL Series Air Atomizing Spray Nozzles

BEX JPL Air Atomizing Spray Nozzles use compressed air (or gas) to produce an accurately controlled liquid dispersion in applications where a conventional liquid spray nozzle would not be suitable. Typical applications include humidification, cooling, air pollution control, coating processes, lubrication, curing, chemical dispersion, and many other uses.

The JPL Series are excellent products for new applications, and are suitable for replacing products in existing atomizing applications. Many of the JPL Series components are interchangeable with products from other manufacturers.

## TYPICAL APPLICATIONS

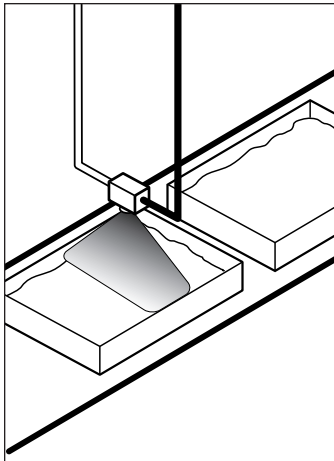

Vitamin/Bacteriostat liquid accurately spray portioned on animal feed.

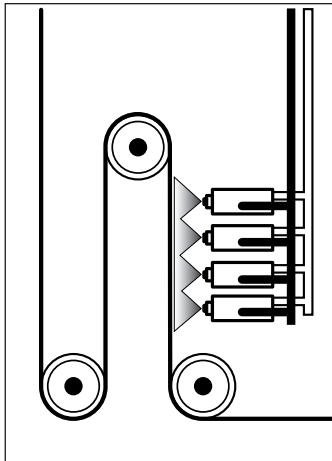

Moisturizing, anti-static application on fabric.

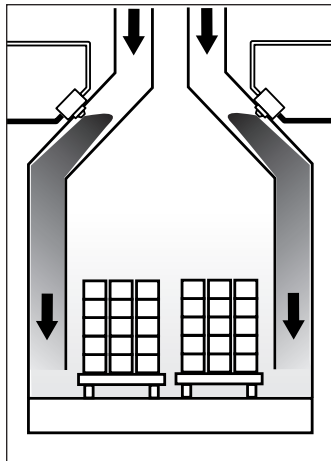

Humidity control in curing ovens, kilns and furnaces.

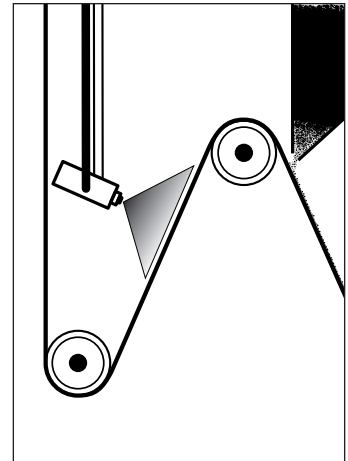

Adhesive application to paper prior to abrasive coating.

BEX also manufactures thousands of other types of spray nozzles...



ZIP-TIP® with Tabz™ Fastest "quick disconnect" style nozzle.



K-Ball® clip on nozzle, no tools required.



BEX Tank Mixing Eductor nozzles improve your tank circulation.



Call for a FREE catalog or e-mail us at: [sales@bex.com](mailto:sales@bex.com).

Visit our Website @ [www.bexspray.com](http://www.bexspray.com)

## AIR ATOMIZING NOZZLE TABLE OF CONTENTS

What is a Standard JPL Assembly? .....	page 1
How to Select a Set-up .....	page 2
Choices of Spray Set-ups and Basic Nozzle Installations .....	page 3
<b>Internal Mix Set-ups</b>	
Round Spray Pattern .....	page 4
Wide-Angle Spray Pattern .....	page 5
Flat Spray Pattern .....	page 5
Siphon/Gravity Feed .....	page 7
<b>External Mix Set-ups</b>	
Flat Spray Pattern .....	page 8-9
Alternative Bodies (Connections) & Mounting .....	page 10
Automatic Air Actuated Nozzle Body Assemblies .....	page 11
How to Order .....	page 12-13

### What is a Standard “JPL” Assembly?



BEX JPL Series Air Atomizing Nozzle with standard 1/4" x 1/4" NPT JPL body. (Other body styles available, see pages 10 & 11.)

BEX offers a full complement of special body connections, wall mounts, shut-off needles, automatic body styles, etc: pages 10-11.



A standard BEX “JPL” assembly consists of seven (7) components that fit together to produce an atomized liquid spray pattern.

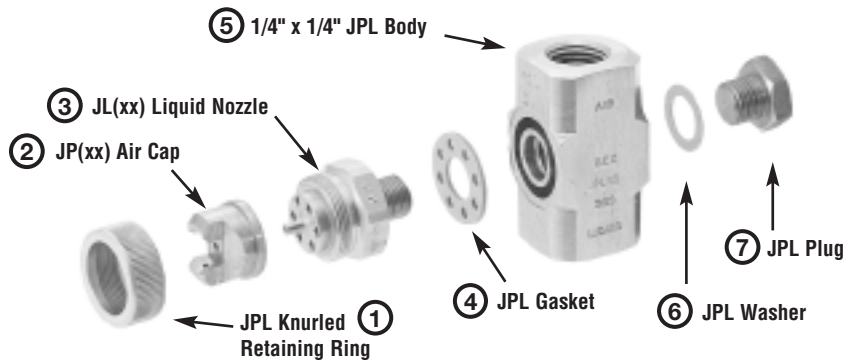

The “JP” Air Cap (2) and “JL” Liquid Nozzle (3) are the components that actually determine the spray pattern and liquid/air flow rates (see diagrams on page 3). We have arranged many of these Air Caps and Liquid Nozzles into a “set-up” (see pages 4-9), which makes it much easier to select a suitable choice for your application.

BEX “JPL” series nozzles and components are available in 303 stainless steel, 316 stainless steel and nickel-plated brass (note: only the external/appearance surfaces of brass components are nickel-plated; see page 13 for more information).

## HOW TO SELECT A SET-UP

All BEX “JPL” Series products are designed to provide a wide range of performance flexibility, allowing the user to adjust the liquid and air feed to the set-up.

By adjusting the liquid and/or air source, a variety of spray droplets and

atomization can be obtained. The performance tables that follow provide spray capacities at certain liquid/air flow combinations for water under standard conditions. These are not by any means the only possible results for each specific set-up.

## How to Select a Set-up

### QUICK REFERENCE

If you know how much liquid flow you desire from the nozzle, but are unsure of the other operating parameters, the tables below provide a quick starting point to determine which set-ups are most frequently chosen to provide the liquid flow rate desired.

#### FLAT SPRAY MODEL SET-UP NO.

GPH*	PRESSURE FED LIQUID	SIPHON FED LIQUID
0.0-0.5	JPL - E15B, E18B, 14, N13	JPL - F1, F2C
0.5-1.0	JPL - E15B, E18B, 14, N13, 13A, 13	JPL - F2C, F3B
1.0-1.5	JPL - E15B, E18B, 14, N13, 13A, 13, E15A, E18A, N23, 23B	JPL - F3B, F4B
1.5-2.5	JPL - E15B, E18B, 14, N13, 13A, 13, E15A, E18A, E15, E18, N23, 23B	JPL - F4B
2.5-3.5	JPL - E15B, E18B, 14, N13, 13A, 13, E15A, E18A, E15, E18, N23, 23B, 23	
3.5-6.0	JPL - E15, E18, E25B, N13, E28B, 12, E15A, E18A, E25A, E28A, N23, 23B, 23	
6.0-9.0	JPL - E15, E18, E25B, 23B, E28B, E28B, 43, E25A, E28A, N23, 23	
9.0-13	JPL - E25, E45B, E25B, E28, E28B, 43, 23, N23, E25A, E28A	
13-20	JPL - E25, E45B, E25B, E28, E28B, 43, 23, N23, E25A, E28A, E45A	
20-30	JPL - E25, E45B, E45, E28, E45A, 43	
30-50	JPL - E25, 43, E45, E28, E45A	
50-70	JPL - E45	
over 70	Please contact your BEX representative	

#### ROUND SPRAY MODEL SET-UP NO.

GPH*	PRESSURE FED LIQUID	SIPHON FED LIQUID
0.0-0.5	JPL - 11, 12A, 16	JPL - 1, 1A, 2A
0.5-1.0	JPL - 11, 12A, 12, 22B, 16, 26B	JPL - 1, 2A, 2
1.0-1.5	JPL - 11, 12A, 12, 22B, 16, 26B, 30	JPL - 2
1.5-2.5	JPL - 11, 12A, 12, 22B, 16, 26B, 26, 30	JPL - 4
2.5-3.5	JPL - 12A, 12, 22B, 16, 26B, 26, 29, 30, 46	JPL - 4, 5
3.5-6.0	JPL - 12, 22B, 22, 26B, 26, 29, 30, 46	JPL - 4, 5
6.0-9.0	JPL - 22B, 22, 26B, 26, 29, 46	JPL - 4, 5
9.0-13	JPL - 22, 26, 29, 42, 46	JPL - 5
13-20	JPL - 22, 26, 29, 42, 46	
20-30	JPL - 22, 42, 46	
30-50	JPL - 42	
50-70	JPL - 42	
over 70	Please contact your BEX Representative	

\* all references to GPH are U.S. gallons per hour.

For detailed performance data please refer to charts on pages 4 to 9.

## CHOICE OF SPRAY SET-UPS

Each spray set-up consists of an air cap and liquid cap which provide a specific spray pattern, capacity and coverage performance. The set-up will produce

comparable spray performance with any of the various bodies available.

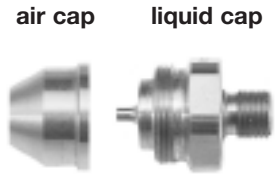

## INTERNAL MIX

Liquid and gas are mixed internally to produce a completely atomized spray. Available in Round, Wide-Angle Round and Flat Spray patterns.

Common uses: Dust control, pesticide application, humidification, cooling, coating and low viscosity fluids.

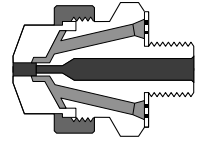

## EXTERNAL MIX

Liquid atomization is controlled by varying the air pressure without changing the liquid pressure. Effective for higher viscosity liquids and abrasive suspensions.

Common uses: Precisely metered applications, adhesives, coatings and viscous fluids.

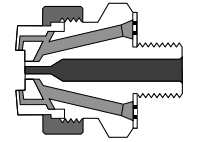

## BASIC NOZZLE INSTALLATIONS

Fine or coarse droplet size atomization is produced by adjusting the air and liquid pressures. Finer atomization is achieved

by increasing air pressure and/or lowering the liquid pressure.

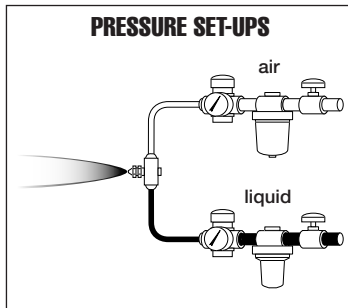

The liquid is supplied to the nozzle under pressure. Air and liquid can be externally or internally mixed to produce the proper atomized spray.

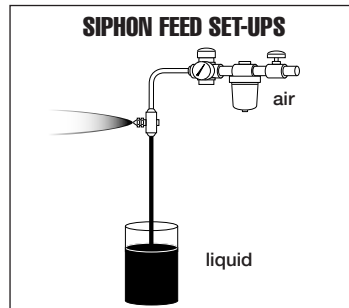

The liquid is supplied by either a liquid siphon or gravity feed. These set-ups are designed to draw liquid through the feed line into the air flow where it is properly atomized.

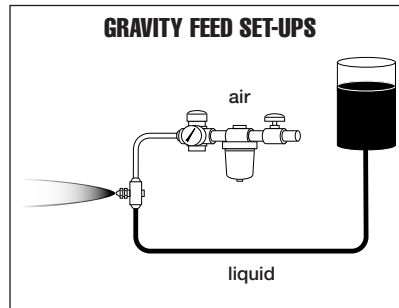

Note: all dimensions/specifications subject to change without notification.

What are you waiting for?

**BEX**<sup>®</sup>  
SPRAY NOZZLES

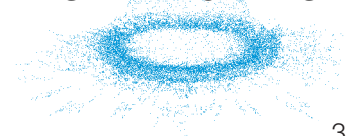

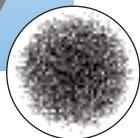
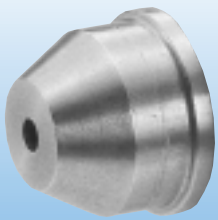

spray pattern

# BEX JPE series round spray

Pressure feed - Internal mix

## APPLICATION AND PERFORMANCE

Set-ups with BEX JPG series air caps produce a round spray pattern. The liquid is pressure fed and internally mixed. Nozzle selection is not limited for other parameters.

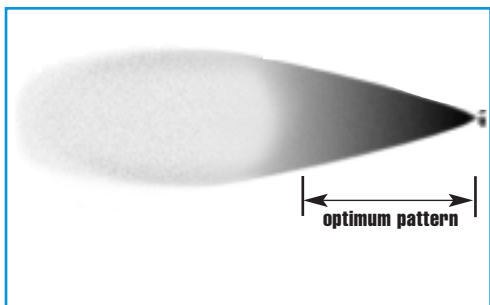

See page 12 and 13 for instructions on how to order.

## JPE Round Spray Performance Chart

BEX Set-up No.	Spray Set-up Consists of Liquid and Air Cap Combination	LIQUID CAPACITY in GPH and AIR CAPACITY in SCFM															SPRAY DIMENSIONS		
		LIQUID PRESSURE in psi															Optimum Pattern		Maximum
		10 psi			20 psi			30 psi			40 psi			60 psi			Spray Angle degrees	Spray Range inches	
Air Press psi	GPH	SCFM	Air Press psi	GPH	SCFM	Air Press psi	GPH	SCFM	Air Press psi	GPH	SCFM	Air Press psi	GPH	SCFM					
JPL11	Liquid Cap JL2050 + Air Cap JPE20	10	.66	.55	14	1.50	.40	24	1.68	.56	32	1.86	.68	50	2.28	.98	13-15	12-17	9-14
		12	.48	.67	18	1.23	.50	28	1.44	.63	36	1.62	.80	54	2.05	1.07			
		14	.36	.78	22	.99	.63	32	1.08	.82	40	1.32	.93	58	1.80	1.19			
		---	---	---	24	.86	.70	36	.84	.96	44	1.08	1.07	62	1.56	1.36			
		---	---	---	26	.72	.76	38	.72	1.03	48	.85	1.23	66	1.32	1.52			
		---	---	---	28	.60	.82	40	.66	1.11	50	.72	1.33	68	1.23	1.58			
JPL12A	Liquid Cap JL2050 + Air Cap JPE40	10	.66	.66	18	1.44	.87	24	1.98	1.00	30	2.40	1.14	40	3.30	1.36	12-15	17-22	12-17
		12	.54	.77	20	1.32	.98	28	1.68	1.17	34	2.16	1.29	46	2.94	1.54			
		14	.42	.90	22	1.20	1.06	32	1.44	1.35	38	1.92	1.47	52	2.58	1.83			
		---	---	---	24	1.08	1.16	34	1.32	1.46	42	1.62	1.68	58	2.28	2.09			
		---	---	---	26	.90	1.26	36	1.20	1.57	44	1.50	1.78	62	2.10	2.26			
		---	---	---	28	1.11	1.66	46	1.38	1.88	66	1.86	2.46	66	1.86	2.46			
JPL12	Liquid Cap JL2850 + Air Cap JPE40	12	1.26	.73	22	2.16	1.05	30	2.90	1.24	36	4.32	1.26	48	5.82	1.50	12-15	19-23	13-17
		16	1.08	.94	26	1.74	1.26	34	2.46	1.42	40	3.85	1.36	52	5.28	1.65			
		20	.90	1.15	30	1.44	1.47	38	2.10	1.65	44	3.55	1.56	56	4.92	1.73			
		22	.81	1.25	34	1.26	1.67	42	1.74	1.87	48	2.80	1.78	60	4.56	1.88			
		24	.78	1.36	38	1.08	1.87	46	1.50	2.03	52	2.46	2.01	64	4.08	2.08			
		26	.77	1.43	40	1.02	1.96	50	1.24	2.25	56	2.16	2.20	68	3.72	2.25			
JPL22B	Liquid Cap JL40100 + Air Cap JPE60	16	3.44	2.68	28	5.03	3.71	40	6.10	4.72	48	7.75	5.30	65	10.7	6.74	18-21	26-38	16-30
		20	2.35	3.20	32	3.70	4.17	44	5.03	5.17	55	5.95	6.07	75	8.67	7.73			
		22	1.90	3.46	36	2.64	4.65	48	3.95	5.65	65	3.55	7.28	80	7.65	8.25			
		24	1.54	3.70	40	1.85	5.13	55	2.30	6.50	75	1.95	8.50	85	6.65	8.80			
		26	1.23	3.97	44	1.30	5.63	60	1.56	7.12	80	1.40	9.10	90	5.64	9.40			
		28	.96	4.22	48	.90	6.10	65	1.08	7.75	85	1.00	9.70	95	4.63	10.0			
JPL22	Liquid Cap JL60100 + Air Cap JPE60	12	8.1	2.00	20	13.6	2.55	30	16.3	3.25	38	19.5	3.74	54	25.7	4.66	17-21	24-36	16-28
		14	6.6	2.32	22	12.0	2.85	34	13.1	3.75	42	16.5	4.20	60	21.8	5.34			
		16	4.9	2.66	24	10.2	3.15	38	9.9	4.32	46	13.6	4.71	65	18.5	5.98			
		18	3.4	3.00	26	8.6	3.45	40	8.7	4.61	50	10.8	5.30	70	15.2	6.68			
		---	---	---	28	7.2	3.75	42	7.6	4.90	52	9.6	5.58	75	12.2	7.80			
		---	---	---	30	5.9	4.05	44	6.6	5.20	54	8.6	5.85	80	10.0	8.14			
JPL42	Liquid Cap JL100150 + Air Cap JPE80	14	11.7	3.05	20	27.5	3.04	28	36.6	3.55	32	49.4	3.31	42	70.6	3.17	19-22	35-46	20-30
		16	8.5	3.60	22	23.0	3.49	30	32.6	3.96	36	42.2	4.10	46	65.0	3.85			
		---	---	---	24	18.0	3.95	32	28.7	4.36	40	35.1	4.90	50	59.0	4.63			
		---	---	---	26	14.4	4.40	34	24.8	4.78	44	28.0	5.66	54	53.2	5.40			
		---	---	---	28	11.3	4.85	36	20.9	5.20	46	24.5	6.05	58	47.4	6.16			
		---	---	---	38	17.5	5.60	48	21.3	6.45	65	37.8	7.54	65	37.8	7.54			

"---" means not recommended at this pressure Note: All references to GPH are U.S. gallons per hour

# BEX JPG series wide-angle round spray

Pressure feed - Internal mix

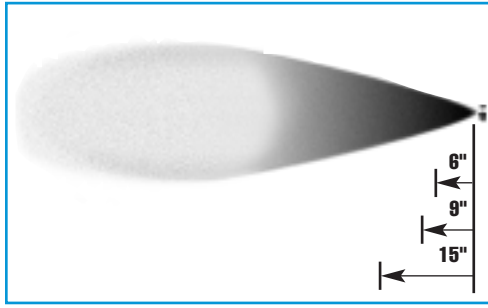

## APPLICATION AND PERFORMANCE

Set-ups with BEX JPE series air caps produce a wide-angle round spray pattern. The liquid is pressure fed and internally mixed. Nozzle selection is not limited for other parameters.

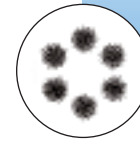

spray pattern

See page 12 and 13 for instructions on how to order.

## JPG Wide-Angle Round Spray Performance Chart

BEX Set-up No.	Spray Set-up Consists of Liquid and Air Cap Combination	LIQUID CAPACITY in GPH and AIR CAPACITY in SCFM															SPRAY DIMENSIONS						
		LIQUID PRESSURE in psi															Pattern Width in Inches			Maximum Spray Range feet			
		10 psi			20 psi			30 psi			40 psi			60 psi			6" from tip	9" from tip	15" from tip				
Air Press psi	GPH	SCFM	Air Press psi	GPH	SCFM	Air Press psi	GPH	SCFM	Air Press psi	GPH	SCFM	Air Press psi	GPH	SCFM	Air Press psi	GPH	SCFM	6" from tip	9" from tip	15" from tip	Maximum Spray Range feet		
JPL16	Liquid Cap JL2050 + Air Cap JPG15	8	1.41	.36	14	2.10	.42	22	2.36	.56	30	2.53	.68	44	2.95	.81							
		10	1.14	.43	16	1.90	.50	26	2.02	.69	34	2.23	.81	48	2.72	.94							
		12	.79	.50	18	1.68	.56	30	1.61	.83	38	1.90	.94	55	2.30	1.20							
		14	.45	.60	20	1.44	.64	34	1.15	1.00	42	1.50	1.1	60	1.92	1.40							
		---	---	---	22	1.17	.71	36	.91	1.07	46	1.10	1.26	65	1.50	1.60							
		---	---	---	24	.91	.80	38	.68	1.16	48	.90	1.35	70	1.07	1.80							
---	---	---	26	.55	.90	40	.43	1.25	50	.69	1.45	75	.65	2.05									
JPL26B	Liquid Cap JL40100 + Air Cap JPG60	12	1.85	1.78	22	3.30	2.30	30	5.10	2.54	38	6.40	2.84	54	8.76	3.44							
		14	.55	2.20	24	2.20	2.67	32	4.25	2.85	42	4.70	3.42	56	8.10	3.74							
		---	---	---	26	1.20	3.05	34	3.35	3.18	44	3.90	3.72	58	7.44	4.03							
		---	---	---	---	---	---	36	2.50	3.50	46	3.06	4.05	60	6.76	4.32							
		---	---	---	---	---	---	38	1.60	3.85	48	2.25	4.42	65	5.10	5.10							
		---	---	---	---	---	---	40	.70	4.30	50	1.40	4.84	70	3.50	6.00							
---	---	---	---	---	---	---	---	---	52	.60	5.34	75	1.85	6.95									
JPL26	Liquid Cap JL60100 + Air Cap JPG60	10	6.3	1.14	20	9.0	1.60	30	11.2	2.04	40	12.4	2.54	56	16.2	2.75							
		12	3.6	1.54	22	6.9	2.00	32	9.3	2.44	42	10.6	2.92	58	14.8	3.11							
		14	2.0	2.00	24	5.1	2.40	34	7.4	2.80	44	8.8	3.33	60	13.8	3.50							
		---	---	---	26	3.3	2.80	36	5.4	3.20	46	7.1	3.72	65	9.8	4.42							
		---	---	---	---	---	---	38	3.6	3.60	48	5.4	4.14	70	6.5	5.36							
		---	---	---	---	---	---	40	2.3	3.98	50	3.6	4.51	75	4.0	6.31							
---	---	---	---	---	---	---	---	---	52	2.2	4.91	80	2.4	6.51									
JPL29	Liquid Cap JL60100 + Air Cap JPG45	18	9.4	3.0	30	13.4	4.15	44	15.3	5.45	60	15.6	7.05	80	21.4	8.55							
		22	7.7	3.6	34	11.9	4.65	48	13.8	5.9	70	12.5	8.25	85	19.5	9.15							
		26	6.0	4.13	38	10.3	5.1	55	11.3	6.75	80	9.3	9.45	90	17.9	9.75							
		28	5.2	4.4	42	8.9	5.6	65	7.8	8.0	85	7.8	10.05	95	16.5	10.35							
		30	4.4	4.7	46	7.3	6.1	70	6.1	8.6	90	6.2	10.7	100	15.1	10.95							
		32	3.7	5.0	50	5.8	6.65	75	4.5	9.25	95	4.8	11.3	---	---	---							
34	3.0	5.25	60	2.4	7.95	80	3.3	9.85	100	3.7	11.9	---	---	---									
JPL30	Liquid Cap JL40100 + Air Cap JPG30	16	3.24	1.43	28	4.60	1.96	42	5.27	2.67	55	5.69	3.30	80	7.10	4.50							
		18	2.61	1.59	32	3.37	2.27	46	4.0	2.96	60	4.24	3.68	85	5.80	4.88							
		20	2.08	1.75	36	2.45	2.55	48	3.45	3.11	65	3.15	4.06	90	4.65	5.27							
		22	1.62	1.90	40	1.75	2.85	50	3.03	3.26	70	2.31	4.44	95	3.75	5.65							
		24	1.30	2.06	42	1.45	3.00	55	2.11	3.63	75	1.72	4.82	100	3.00	6.03							
		26	1.04	2.20	44	1.21	3.14	60	1.47	3.98	80	1.32	5.20	---	---	---							
28	.82	2.35	46	1.0	3.28	65	1.03	4.36	85	1.05	5.58	---	---	---									
JPL46	Liquid Cap JL100150 + Air Cap JPG75	24	6.7	5.5	38	10.7	7.4	48	16.5	8.8	60	18.6	10.4	85	29.2	13.7							
		26	5.2	5.9	42	7.6	8.3	52	12.5	9.6	65	13.7	11.4	90	24.6	14.7							
		28	4.0	6.3	44	6.2	8.7	56	9.2	10.4	70	10.0	12.4	95	20.7	15.8							
		30	3.0	6.8	46	5.0	9.1	60	6.6	11.3	75	7.4	13.5	100	17.5	16.9							
		32	2.0	7.2	48	4.0	9.5	62	5.6	11.7	80	5.5	14.5	---	---	---							
		---	---	---	50	3.0	9.9	65	4.4	12.3	85	4.0	15.5	---	---	---							
---	---	---	52	2.4	10.3	70	2.6	13.3	90	2.5	16.6	---	---	---									

“---” means not recommended at this pressure Note: All references to GPH are U.S. gallons per hour

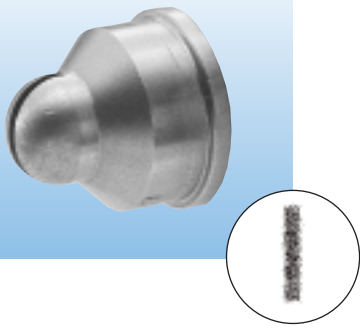

spray pattern

# BEX JPD series flat spray

Pressure feed - Internal mix

## APPLICATION AND PERFORMANCE

Set-ups with BEX JPD series air caps produce a flat spray pattern. The liquid is pressure fed and internally mixed. Nozzle selection is not limited for other parameters.

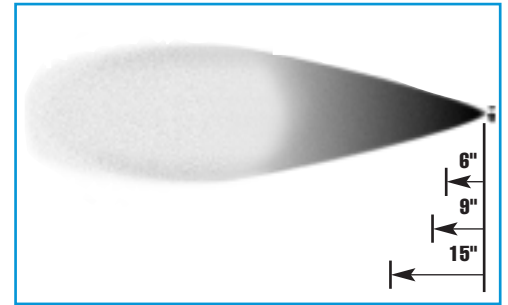

See page 12 and 13 for instructions on how to order.

## JPD Flat Spray Performance Chart

BEX Set-up No.	Spray Set-up Consists of Liquid and Air Cap Combination	LIQUID CAPACITY in GPH and AIR CAPACITY in SCFM															SPRAY DIMENSIONS			
		LIQUID PRESSURE in psi															Pattern Width in Inches			Maximum Spray Range feet
		10 psi			20 psi			30 psi			40 psi			60 psi			6" from tip	9" from tip	15" from tip	
Air Press. psi	GPH	SCFM	Air Press. psi	GPH	SCFM	Air Press. psi	GPH	SCFM	Air Press. psi	GPH	SCFM	Air Press. psi	GPH	SCFM	Air Press. psi	GPH	SCFM			
JPL13A	Liquid Cap JL2050 + Air Cap JPD30	10	1.44	.84	18	2.17	1.12	28	2.49	1.47	38	2.77	1.84	55	3.41	2.43	10-22	14-29	18-37	8-13
		12	1.25	.96	22	1.82	1.31	32	2.19	1.64	42	2.49	2.01	65	2.83	2.85				
		14	1.09	1.08	26	1.50	1.50	36	1.89	1.82	46	2.20	2.19	75	2.26	3.26				
		16	.93	1.20	30	1.20	1.68	40	1.58	2.00	50	1.93	2.37	85	1.69	3.67				
		18	.79	1.32	34	.93	1.87	44	1.30	2.18	60	1.25	2.81	90	1.40	3.88				
		20	.65	1.43	38	.68	2.07	48	1.03	2.36	65	.93	3.02	95	1.13	4.09				
22	.53	1.55	40	.57	2.16	55	.65	2.68	70	.65	3.25	100	.88	4.29						
JPL13	Liquid Cap JL2850 + Air Cap JPD30	12	2.17	.70	20	3.35	.96	30	3.98	1.27	38	4.66	1.49	65	4.8	2.38	14-23	18-30	28-38	7-10
		14	1.80	.82	24	2.71	1.14	34	3.41	1.45	42	4.14	1.65	70	4.21	2.62				
		16	1.45	.95	28	2.06	1.34	38	2.85	1.64	46	3.6	1.85	75	3.63	2.86				
		18	1.08	1.07	30	1.76	1.45	42	2.29	1.85	50	3.08	2.05	80	3.05	3.10				
		20	.77	1.2	32	1.44	1.56	46	1.72	2.07	60	1.76	2.58	85	2.48	3.35				
		---	---	---	34	1.18	1.67	48	1.43	2.18	65	1.2	2.84	90	1.98	3.60				
---	---	---	36	.94	1.78	50	1.2	2.28	70	.76	3.09	95	1.57	3.85						
JPLN13	Liquid Cap JL2850 + Air Cap JPD45	14	2.4	.89	22	3.2	1.13	34	3.4	1.63	40	4.4	1.77	60	5.0	2.53	4-8	5-10	7-13	10-16
		16	2.1	1.05	26	2.8	1.38	38	2.9	1.86	44	3.8	1.99	65	4.4	2.73				
		18	1.7	1.14	30	2.1	1.62	42	2.3	2.07	48	3.3	2.22	70	3.9	3.00				
		20	1.4	1.26	34	1.5	1.87	46	1.8	2.36	54	2.6	2.55	75	3.4	3.25				
		24	.81	1.54	38	1.2	2.1	50	1.4	2.58	60	1.9	2.98	80	3.0	3.57				
		28	.54	1.76	42	.72	2.38	60	.60	3.16	70	1.1	3.53	90	2.3	4.12				
32	.30	1.96	48	.39	2.69	70	.33	3.65	85	.40	4.27	100	2.0	4.65						
JPL14	Liquid Cap JL2850 + Air Cap JPD15	18	1.04	1.05	30	1.56	1.43	42	2.06	1.75	55	2.16	2.15	75	3.20	2.66	10-25	13-30	18-38	6-7
		20	.80	1.15	34	1.10	1.61	44	1.80	1.85	60	1.60	2.38	80	2.66	2.90				
		22	.62	1.25	36	.90	1.70	46	1.57	1.94	65	1.15	2.62	85	2.19	3.13				
		24	.47	1.35	38	.74	1.79	48	1.35	2.04	70	.76	2.85	90	1.75	3.36				
		26	.35	1.45	40	.60	1.88	50	1.13	2.13	---	---	---	---	---	---				
		28	.25	1.55	42	.47	1.97	55	.70	2.36	---	---	---	---	---	---				
---	---	---	44	.35	2.07	---	---	---	---	---	---	---	---	---						
JPLN23	Liquid Cap JL60100 + Air Cap JPD75	14	4.5	.80	24	7.5	1.24	34	9.5	1.74	44	11.1	2.2	56	19.8	2.56	4-8	5-10	6-14	8-13
		16	2.9	.97	26	6.0	1.44	36	7.8	1.96	46	9.7	2.46	60	16.7	2.97				
		18	2.0	1.17	28	4.5	1.68	38	6.5	2.2	48	8.4	2.69	65	13.5	3.5				
		20	.84	1.42	30	3.4	1.82	40	5.2	2.53	52	5.7	3.3	70	9.7	4.33				
		---	---	---	32	2.4	2.06	42	4.1	2.65	56	3.9	3.84	80	4.8	5.73				
		---	---	---	34	1.3	2.32	46	2.6	3.25	60	2.4	4.36	90	1.8	7.4				
---	---	---	36	.80	2.61	50	1.1	3.72	65	1.1	5.04	95	.70	8.38						
JPL23B	Liquid Cap JL40100 + Air Cap JPD60	16	2.95	1.92	28	4.45	2.66	38	5.94	3.22	46	7.50	3.66	65	9.70	4.80	6-13	7-16	8-19	10-13
		18	2.25	2.10	30	3.87	2.84	40	5.40	3.40	50	6.45	3.97	70	8.60	5.20				
		20	1.72	2.30	32	3.30	3.04	42	4.86	3.55	52	5.90	4.15	75	7.50	5.60				
		22	1.32	2.50	34	2.78	3.22	44	4.32	3.74	54	5.40	4.32	80	6.40	6.00				
		24	1.00	2.70	36	2.28	3.40	46	3.78	3.93	56	4.87	4.50	85	5.30	6.48				
		---	---	---	---	---	---	48	3.25	4.12	58	4.34	4.70	90	4.25	6.96				
---	---	---	---	---	---	---	---	---	60	3.84	4.90	---	---	---						
JPL23	Liquid Cap JL60100 + Air Cap JPD60	12	7.0	1.15	22	11.5	1.65	34	12.4	2.20	46	13.7	2.75	65	18.3	3.56	7-13	9-16	12-20	11-14
		14	5.4	1.35	26	8.3	2.02	38	9.8	2.57	50	10.9	3.14	75	12.6	4.47				
		16	4.2	1.57	30	6.0	2.40	42	7.8	2.95	54	8.7	3.51	80	10.6	4.95				
		18	3.3	1.69	32	5.1	2.60	46	5.9	3.34	56	7.8	3.70	85	8.7	5.40				
		20	2.7	1.97	34	4.3	2.78	48	5.0	3.52	60	6.4	4.06	90	6.9	5.85				
		22	2.0	2.20	36	3.6	2.97	50	4.3	3.71	65	4.6	4.53	95	5.5	6.30				
---	---	---	38	3.0	3.16	52	3.7	3.90	70	3.3	5.00	100	4.5	6.76						
JPL43	Liquid Cap JL100150 + Air Cap JPD90	14	7.7	3.17	26	10.5	4.55	34	20.8	4.75	42	29.4	5.15	58	44.7	6.05	7-14	8-17	10-23	11-17
		16	5.0	3.83	28	7.0	5.15	36	16.6	5.25	44	25.1	5.6	60	41.0	6.42				
		---	---	---	---	---	---	38	12.8	5.8	46	20.8	6.05	65	31.4	7.45				
		---	---	---	---	---	---	40	9.5	6.35	48	16.7	6.6	70	22.5	8.75				
		---	---	---	---	---	---	42	6.7	6.85	50	13.1	7.15	75	15.0	10.1				
		---	---	---	---	---	---	---	---	---	52	10.0	7.75	80	8.7	11.45				
---	---	---	---	---	---	---	---	---	54	7.3	8.3	---	---	---						

"---" means not recommended at this pressure

Note: All references to GPH are U.S. gallons per hour

# BEX JPV series round & JPK series flat spray

Siphon/Gravity feed

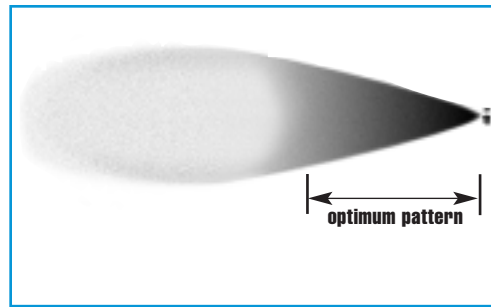

## APPLICATION AND PERFORMANCE

Set-ups with BEX JPV and JPK series air caps produce round and flat spray patterns respectively. The liquid is gravity or siphon fed into the airstream. Nozzle selection is not limited for other parameters. If you do not find the product for your application, please contact BEX.

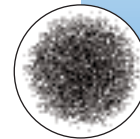

spray pattern



See page 3 for siphon and gravity feed installation.  
See page 12 and 13 for instructions on how to order.

## JPV Round Spray Performance Chart

BEX Set-up No.	Spray Set-up Consists of Liquid and Air Cap Combination	ATOMIZING AIR		LIQUID CAPACITY in GPH								SPRAY DIMENSIONS (at 8" siphon height)		
		Air Press psi	Air Capacity SCFM	Gravity Head			Siphon Height					Optimum Pattern		Max. Spray Range feet
				18"	12"	6"	4"	8"	12"	24"	36"	Spray Angle degrees	Spray Range inches	
JPL1A	Liquid Cap JL1650 + Air Cap JPV20	10	.40	.39	.35	.30	.23	.18	.14	---	---	18	11-14	6-8
		20	.59	.46	.43	.39	.34	.31	.28	.14	---			
		40	.95	.54	.50	.47	.41	.38	.36	.28	.19			
		60	1.32	.59	.54	.49	.44	.41	.39	.31	.24			
JPL1	Liquid Cap JL2050 + Air Cap JPV20	10	.47	.63	.55	.46	.40	.32	.21	---	---	18-19	12-17	7-10
		20	.66	.73	.66	.60	.54	.48	.40	.21	.07			
		40	1.06	.87	.81	.76	.71	.67	.61	.43	.28			
		60	1.48	.98	.92	.88	.83	.79	.73	.57	.40			
JPL2A	Liquid Cap JL2050 + Air Cap JPV40	10	.81	.67	.61	.53	.43	.37	.29	---	---	18-20	12-17	8-13
		20	1.20	.76	.72	.64	.56	.50	.44	.21	---			
		40	1.94	.89	.86	.82	.76	.71	.65	.46	.30			
		60	2.70	.98	.96	.94	.91	.87	.81	.68	.56			
JPL2	Liquid Cap JL2850 + Air Cap JPV40	10	.68	1.19	1.05	.91	.56	.47	.38	---	---	21-22	15-20	10-15
		20	1.03	1.37	1.27	1.13	.88	.77	.68	.46	---			
		40	1.70	1.57	1.47	1.32	1.15	1.05	.91	.63	.28			
		60	2.39	1.48	1.41	1.30	1.08	1.02	.90	.74	.52			
JPL4	Liquid Cap JL60100 + Air Cap JPV60	20	1.90	5.80	5.15	4.20	3.10	2.65	1.90	.60	---	17-19	18-23	12-18
		40	3.00	6.50	5.95	5.10	4.30	3.70	3.00	1.55	.70			
		60	4.10	6.80	6.35	5.60	4.90	4.20	3.45	2.20	1.30			
		80	5.20	6.80	6.40	5.80	5.20	4.50	3.85	2.60	1.60			
JPL5	Liquid Cap JL100150 + Air Cap JPV80	30	5.3	---	---	---	7.2	6.0	4.6	---	---	20-22	20-25	22-27
		40	6.5	---	---	---	7.8	6.8	5.3	---	---			
		60	8.8	---	11.4	10.6	8.3	7.4	6.2	3.2	---			
		80	11.1	11.6	11.0	10.3	8.3	7.5	6.4	4.4	2.2			

(see spray diagram on page 6)

spray pattern

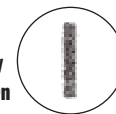

## JPK Flat Spray Performance Chart

BEX Set-up No.	Spray Set-up Consists of Liquid and Air Cap Combination	ATOMIZING AIR		LIQUID CAPACITY in GPH								SPRAY DIMENSIONS (at 8" siphon height)			
		Air Press psi	Air Capacity SCFM	Gravity Head			Siphon Height					Optimum Pattern			Spray Range feet
				18"	12"	6"	4"	8"	12"	24"	36"	6" from tip	9" from tip	15" from tip	
JPLF1	Liquid Cap JL2850 + Air Cap JPK20	10	.99	.35	.33	.30	.27	.25	.22	.17	.13	8-9	10-12	15	6-7
		20	1.42	.31	.30	.29	.26	.25	.23	.19	.16				
		30	1.83	.18	.16	.15	.11	.09	---	---	---				
JPLF2C	Liquid Cap JL35100 + Air Cap JPK40	20	1.86	1.01	.95	.90	.77	.72	.67	.62	.56	9-11	12-15	15-19	9-10
		30	2.42	.88	.84	.81	.75	.71	.67	.63	.57				
		40	2.96	.76	.73	.69	.65	.61	.58	.53	.48				
		60	4.05	.44	.41	.37	.33	.30	.27	---	---				
JPLF3B	Liquid Cap JL40100 + Air Cap JPK60	20	2.26	1.35	1.28	1.20	1.01	.96	.92	.78	.62	7-8	9-10	10-12	10-11
		30	2.88	1.26	1.21	1.14	.92	.87	.82	.74	.59				
		40	3.52	.98	.92	.87	.66	.59	.52	.44	---				
		50	4.13	.58	.52	.44	---	---	---	---	---				
JPLF4B	Liquid Cap JL40100 + Air Cap JPK80	20	2.10	2.01	1.90	1.71	1.47	1.40	1.32	1.17	.92	6-8	8-10	10-13	11
		30	2.70	2.00	1.94	1.81	1.58	1.52	1.45	1.34	1.11				
		40	3.28	1.82	1.74	1.63	1.42	1.34	1.22	1.03	---				
		50	3.87	1.10	.97	.85	.69	---	---	---	---				

--- means not recommended at this pressure      Note: All references to GPH are U.S. gallons per hour

# BEX JPT series flat spray

Pressure feed - External mix

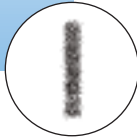

spray pattern

## APPLICATION AND PERFORMANCE

BEX JPT series air caps produce a flat spray pattern. Liquid is pressure fed and externally mixed. Nozzle selection is not limited for other parameters. If you do not find the product for your application range, please contact BEX.

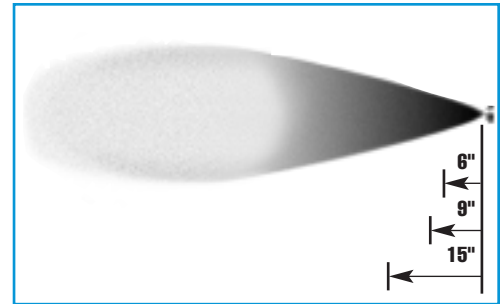

See page 12 and 13 for instructions on how to order.

## JPT Flat Spray Performance Chart

BEX Set-up No.	Spray Set-up Consists of Liquid and Air Cap Combination	LIQUID CAPACITY in GPH and AIR CAPACITY in SCFM														SPRAY DIMENSIONS					
		LIQUID PRESSURE in psi														Pattern Width in Inches			Maximum Spray Range feet		
		3 psi			5 psi			10 psi			20 psi			40 psi			6" from tip	9" from tip		15" from tip	
Air Press. psi	SCFM	GPH	Air Press. psi	SCFM	GPH	Air Press. psi	SCFM	GPH	Air Press. psi	SCFM	GPH	Air Press. psi	SCFM	GPH	Air Press. psi	SCFM	GPH	6" from tip	9" from tip	15" from tip	Spray Range feet
JPLE15B	Liquid Cap JL1650 + Air Cap JPT15	3	.89	.80	5	.93	1.1	10	1.1	1.4	20	1.6	2.0	40	2.6	2.8	3-6	6-7	9-11	3-8	
		5	.93	.80	10	1.1	1.0	15	1.4	1.4	25	1.9	2.0	50	3.0	2.8					
		10	1.1	.80	15	1.4	1.0	20	1.6	1.4	30	2.1	2.0	60	3.6	2.8					
		15	1.4	.80	20	1.6	1.0	25	1.9	1.4	40	2.6	2.0	70	4.2	2.8					
		20	1.6	.80	25	1.9	1.0	30	2.1	1.4	50	3.0	2.0	75	4.5	2.8					
		25	1.9	.80	30	2.1	1.0	40	2.6	1.4	60	3.6	2.0	80	4.9	2.8					
JPLE18B	Liquid Cap JL1650 + Air Cap JPT30	30	2.1	.80	40	2.6	1.0	50	3.0	1.4	80	4.9	2.0	90	5.6	2.8	8-12	11-15	13-20	4-9	
		5	.78	.80	5	.78	1.0	6	.88	1.4	8	1.0	2.0	10	1.2	2.8					
		6	.88	.80	6	.88	1.0	8	1.0	1.4	10	1.2	2.0	15	1.6	2.8					
		7	.97	.80	8	1.0	1.0	10	1.2	1.4	15	1.6	2.0	25	2.2	2.8					
JPLE15A	Liquid Cap JL2050 + Air Cap JPT15	8	1.0	.80	10	1.2	1.0	12	1.4	1.4	20	1.9	2.0	35	2.8	2.8	3-6	5-8	8-12	3-10	
		5	.93	1.2	10	1.1	1.6	15	1.4	2.2	25	1.9	3.1	45	2.9	4.4					
		10	1.1	1.2	15	1.4	1.6	20	1.6	2.2	30	2.1	3.1	50	3.0	4.4					
		15	1.4	1.2	20	1.6	1.6	25	1.9	2.2	40	2.6	3.1	60	3.6	4.4					
		20	1.6	1.2	25	1.9	1.6	30	2.1	2.2	50	3.0	3.1	70	4.2	4.4					
		25	1.9	1.2	30	2.1	1.6	40	2.6	2.2	60	3.6	3.1	75	4.5	4.4					
		30	2.1	1.2	40	2.6	1.6	50	3.0	2.2	70	4.2	3.1	90	5.6	4.4					
JPLE18A	Liquid Cap JL2050 + Air Cap JPT30	40	2.6	1.2	50	3.0	1.6	60	3.6	2.2	90	5.6	3.1	95	5.8	4.4	11-16	13-19	16-26	5-10	
		5	.78	1.2	5	.78	1.6	8	1.0	2.2	10	1.2	3.1	15	1.6	4.4					
		8	1.0	1.2	10	1.2	1.6	10	1.2	2.2	20	1.9	3.1	20	1.9	4.4					
		10	1.2	1.2	15	1.6	1.6	20	1.9	2.2	30	2.5	3.1	30	2.5	4.4					
JPLE15	Liquid Cap JL2850 + Air Cap JPT15	15	1.6	1.2	20	1.9	1.6	30	2.5	2.2	35	2.8	3.1	35	2.8	4.4	5-6	6-8	9-14	4-13	
		10	1.1	2.3	15	1.4	3.0	20	1.6	4.2	35	2.4	6.0	50	3.0	8.4					
		15	1.4	2.3	20	1.6	3.0	25	1.9	4.2	40	2.6	6.0	60	3.6	8.4					
		20	1.6	2.3	25	1.9	3.0	30	2.1	4.2	50	3.0	6.0	70	4.2	8.4					
		25	1.9	2.3	30	2.1	3.0	40	2.6	4.2	60	3.6	6.0	75	4.5	8.4					
		30	2.1	2.3	40	2.6	3.0	50	3.0	4.2	70	4.2	6.0	80	4.9	8.4					
JPLE18	Liquid Cap JL2850 + Air Cap JPT30	40	2.6	2.3	50	3.0	3.0	60	3.6	4.2	80	4.9	6.0	90	5.6	8.4	14-17	19-21	24-27	6-9	
		50	3.0	2.3	60	3.6	3.0	70	4.2	4.2	90	5.6	6.0	100	6.2	8.4					
		6	.88	2.3	6	.88	3.0	6	.88	4.2	10	1.2	6.0	20	1.9	8.4					
		7	.97	2.3	8	1.0	3.0	8	1.0	4.2	12	1.4	6.0	25	2.2	8.4					
JPLE25B	Liquid Cap JL35100 + Air Cap JPT45	8	1.0	2.3	9	1.1	3.0	10	1.2	4.2	15	1.6	6.0	30	2.5	8.4	5-6	7-9	10-14	5-16	
		10	1.2	2.3	10	1.2	3.0	12	1.4	4.2	20	1.9	6.0	35	2.8	8.4					
		10	3.0	3.6	15	3.6	4.7	20	4.1	6.6	35	6.3	9.4	45	7.5	13.2					
		15	3.6	3.6	20	4.1	4.7	25	4.9	6.6	40	6.9	9.4	50	8.2	13.2					
		20	4.1	3.6	25	4.9	4.7	30	5.5	6.6	50	8.0	9.4	55	9.0	13.2					
		25	4.9	3.6	30	5.5	4.7	35	6.3	6.6	60	9.4	9.4	60	9.7	13.2					
30	5.5	3.6	40	6.9	4.7	40	6.9	6.6	70	11.0	9.4	70	11.1	13.2							
40	6.9	3.6	50	8.0	4.7	50	8.0	6.6	80	12.7	9.4	80	12.7	13.2							
50	8.0	3.6	60	9.4	4.7	60	9.4	6.6	90	14.5	9.4	90	14.5	13.2							

Note: All references to GPH are U.S. gallons per hour

### JPT Flat Spray Performance Chart (continued)

BEX Set-up No.	Spray Set-up Consists of Liquid and Air Cap Combination	LIQUID CAPACITY in GPH and AIR CAPACITY in SCFM															SPRAY DIMENSIONS				
		LIQUID PRESSURE in psi															Optimum Pattern Width in Inches			Maximum	
		3 psi			5 psi			10 psi			20 psi			40 psi			6" from tip	9" from tip	15" from tip	Spray Range feet	
Air Press. psi	SCFM	GPH	Air Press. psi	SCFM	GPH	Air Press. psi	SCFM	GPH	Air Press. psi	SCFM	GPH	Air Press. psi	SCFM	GPH	Air Press. psi	SCFM	GPH				
JPLE28B	Liquid Cap JL35100 + Air Cap JPT60	8	3.2	3.6	10	3.6	4.7	20	5.5	6.6	30	7.4	---	45	10.0	13.2	13-16	15-20	19-28	12-17	
		10	3.6	3.6	15	4.6	4.7	30	7.4	6.6	40	9.1	---	60	12.6	13.2					
		15	4.6	3.6	25	6.5	4.7	35	8.3	6.6	50	10.9	---	75	15.2	13.2					
		20	5.5	3.6	30	7.4	4.7	40	9.1	6.6	60	12.6	---	80	16.0	13.2					
JPLE25A	Liquid Cap JL40100 + Air Cap JPT45	10	3.0	4.8	20	4.1	6.1	25	4.9	8.7	40	6.9	---	50	8.2	17.4	6-7	7-10	10-14	7-19	
		15	3.6	4.8	25	4.9	6.1	30	5.5	8.7	45	7.5	---	60	9.7	17.4					
		20	4.1	4.8	30	5.5	6.1	35	6.3	8.7	50	8.0	---	70	11.1	17.4					
		25	4.9	4.8	35	6.3	6.1	40	6.9	8.7	60	9.4	12.3	75	12.0	17.4					
		30	5.5	4.8	40	6.9	6.1	50	8.0	8.7	70	11.0	---	80	12.7	17.4					
		40	6.9	4.8	50	8.0	6.1	60	9.4	8.7	80	12.7	---	90	14.5	17.4					
JPLE28A	Liquid Cap JL40100 + Air Cap JPT60	8	3.2	4.8	10	3.6	6.1	15	4.6	8.7	35	8.3	---	50	10.9	17.4	12-15	15-19	20-25	10-17	
		15	4.6	4.8	20	5.5	6.1	25	6.5	8.7	45	10.0	---	65	13.5	17.4					
		20	5.5	4.8	25	6.5	6.1	35	8.3	8.7	55	11.7	---	85	16.8	17.4					
		25	6.5	4.8	30	7.4	6.1	40	9.1	8.7	60	12.6	---	95	18.5	17.4					
JPLE28	Liquid Cap JL60100 + Air Cap JPT60	10	3.6	9.9	15	4.6	6.1	25	6.5	18.0	45	10.0	25.5	75	15.2	36.0	15-19	20-25	26-33	12-19	
		15	4.6	9.9	20	5.5	6.1	30	7.4	18.0	50	10.9	25.5	85	16.8	36.0					
		20	5.5	9.9	30	7.4	6.1	40	9.1	18.0	70	14.3	25.5	95	18.5	36.0					
		25	6.5	9.9	35	8.3	6.1	45	10.0	18.0	80	16.0	25.5	100	19.4	36.0					
JPLE25	Liquid Cap JL60100 + Air Cap JPT45	15	3.6	9.9	25	4.9	12.7	35	6.3	18.0	45	7.5	25.5	55	9.0	36.0	6-8	8-11	10-15	9-19	
		20	4.1	9.9	30	5.5	12.7	40	6.9	18.0	50	8.0	25.5	60	9.7	36.0					
		25	4.9	9.9	35	6.3	12.7	45	7.5	18.0	55	8.7	25.5	65	10.5	36.0					
		30	5.5	9.9	40	6.9	12.7	50	8.0	18.0	60	9.4	25.5	70	11.1	36.0					
		35	6.3	9.9	45	7.5	12.7	60	9.4	18.0	70	11.0	25.5	80	12.7	36.0					
		40	6.9	9.9	50	8.0	12.7	70	11.0	18.0	80	12.7	25.5	90	14.5	36.0					
JPLE45B	Liquid Cap JL60150 + Air Cap JPT75	25	8.3	10.0	25	8.3	12.9	35	10.5	18.0	55	14.5	25.5	---	---	---	6-7	8-9	11-13	10-18	
		30	9.2	10.0	30	9.2	12.9	40	11.6	18.0	60	15.7	25.5	---	---	---					
		35	10.5	10.0	35	10.5	12.9	45	12.5	18.0	65	17.0	25.5	---	---	---					
		40	11.6	10.0	40	11.6	12.9	50	13.4	18.0	70	18.4	25.5	---	---	---					
		45	12.5	10.0	45	12.5	12.9	55	14.5	18.0	75	20.0	25.5	---	---	---					
		50	13.4	10.0	50	13.4	12.9	60	15.7	18.0	80	21.2	25.5	---	---	---					
JPLE45A	Liquid Cap JL80150 + Air Cap JPT75	60	15.7	10.0	60	15.7	12.9	70	18.4	18.0	90	24.2	25.5	---	---	---	6-8	9-10	13-15	11-20	
		30	9.2	17.4	40	11.6	22.5	55	14.5	31.5	70	18.4	44.7	---	---	---					
		35	10.5	17.4	45	12.5	22.5	60	15.7	31.5	75	20.0	44.7	---	---	---					
		40	11.6	17.4	50	13.4	22.5	65	17.0	31.5	80	21.2	44.7	---	---	---					
		45	12.5	17.4	55	14.5	22.5	70	18.4	31.5	85	22.5	44.7	---	---	---					
		50	13.4	17.4	60	15.7	22.5	75	20.0	31.5	90	24.2	44.7	---	---	---					
JPLE45	Liquid Cap JL100150 + Air Cap JPT75	60	15.7	17.4	70	18.4	22.5	80	21.2	31.5	---	---	---	---	---	---	7-8	10-11	14-16	15-20	
		70	18.4	17.4	80	21.2	22.5	90	24.2	31.5	---	---	---	---	---	---					
		40	11.6	27.9	50	13.4	36.0	65	17.0	50.6	80	21.2	72.0	---	---	---					
		45	12.5	27.9	55	14.5	36.0	70	18.4	50.6	85	22.5	72.0	---	---	---					
		50	13.4	27.9	60	15.7	36.0	75	20.0	50.6	90	24.2	72.0	---	---	---					
		55	14.5	27.9	65	17.0	36.0	80	21.2	50.6	---	---	---	---	---	---					

“---” means not recommended at this pressure Note: All references to GPH are U.S. gallons per hour

# Alternative Bodies (Connections) and Mounting

For specific application details, please contact BEX.

## TOP-CONNECT BODY



**2JTPL - 1/4" Top-Connect JPL Body**  
Air (gas) and liquid inlets are both on top of this body, 90° from the nozzle outlet.

## BACK-CONNECT BODY



**2JBPL - 1/4" Back-Connect JPL Body**  
Air (gas) and liquid inlets are on back of this body, 180° from the nozzle outlet.

## THICK WALL MOUNT



**JPLM -**  
Wall adapter replaces the cap retaining ring with a 3/4" MNPT adapter which allows mounting any JPL assembly to a thick wall (over 3/8" thick).

## THIN WALL MOUNT



**JPLN -**  
Thin wall adaptation, simply add a PLMN locking nut and PLMG o-ring to the JPLM thick wall adapter, and you can mount any JPL assembly to a wall less than 3/8" thick.

(1-1/16" clearance hole required)

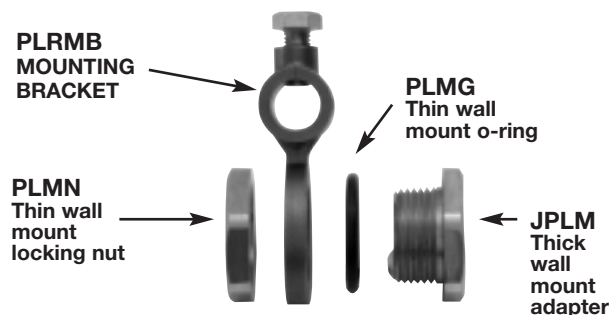

**PLRMB -**  
The rod mounting bracket allows for any air atomizing body to be mounted to a 1/2" diameter steel rod. Simply use the hardware from the thin wall mount (JPLN).

BEX Automatic Air Actuated Spray Nozzles can be fitted with any BEX spray set-ups to meet your atomizing needs. Liquid flow to the nozzle assembly may be either pressure, gravity or siphon fed. The flow is precisely controlled through an automatically operated air cylinder inside the body. For specific application details please contact BEX. Typical applications include: moistening, die lubrication, coatings, pattern lubrication, paper mills, and many others.

# Automatic Air Actuated Nozzle Body Assemblies



## STANDARD AUTOMATIC BODY

**2JAPL -**

Automatic Body



**2JAFPL -**

Automatic Body with Manual Shut-off



## SINGLE AIR LINE AUTOMATIC BODY

**2JSPL -**

Single Air Line Automatic Body



**2JSFPL -**

Single Air Line Automatic Body with Manual Shut-off



## EXTENSIONS (FOR JA SERIES BODY)

**2JAX6PL - 6" Extension**

**2JAX12PL - 12" Extension**

These extensions allow the spray tip to be positioned 6" or 12" away from the body.

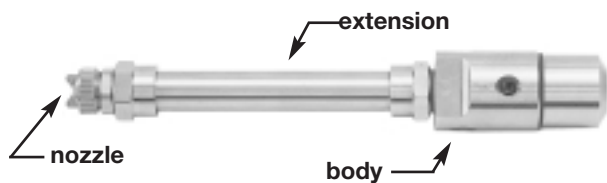

## EXTENSIONS (FOR JPL, JTPL, JBPL BODIES)

**JX6PL - 6" Extension**  
**JX12PL - 12" Extension**

These extensions allow the spray tip to be positioned 6" or 12" away from the body.

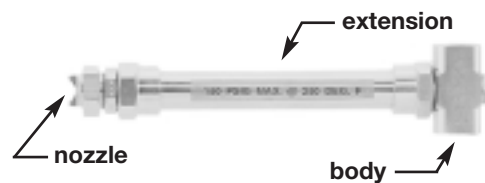



## How to Order

We have designed these two pages to help you select a model number for easy ordering. If you would like help in choosing the proper assembly to order, please give us a call and we will be happy to assist you.

To order any “JPL” assembly choose from the following:

FITTING CODE	
Code	Description
2	1/4" x 1/4" NPT
B2	1/4" x 1/4" BSPT

Note: 1/8" NPT and BSPT are available. Contact BEX for ordering information.

BODY CODE	
Code	Description
<i>STANDARD BODIES</i>	
JPL	Standard Body
JTPL	Top-Connect Body
JBPL	Back-Connect Body
JMPL	Thick Wall
JNPL	Thin Wall
JX6PL	6" Extension
JX12PL	12" Extension
<i>AUTOMATIC AIR-ACTUATED BODIES</i>	
JAPL	Automatic Body
JAFPL	Automatic/with Shut-Off
JSPL	Single-Airline Automatic
JSFPL	Single-Air/with Shut-Off
JAX6PL	6" Extended-Automatic
JAX12PL	12" Extended-Automatic

## Examples of “JPL” assembly model numbers.

FITTING CODE	BODY CODE	SET-UP CODE	OPTION CODES*	MATERIAL CODE
2	JPL	12		3
<p>2JPL12 3, is a standard JPL assembly consisting of: 1/4" x 1/4" NPT fitting standard JPL body; knurled retaining ring, rear plug, fiber gasket and fiber washer; JPE40 air cap and JL2850 liquid nozzle in 303 stainless steel.</p>				
2	JSPL	12	T	6
<p>2JSPL12T 6, is a single airline automatic JPL assembly consisting of: 1/4" x 1/4" NPT fitting single airline automatic JSPL body; knurled retaining ring; and Teflon® gasket; JPE40 air cap and JL2850 liquid nozzle in 316 stainless steel.</p>				

Note: When ordering always leave a space between the model number and material code. Example: 2JPL12 3

SET-UP CODE		OPTION CODES*		MATERIAL CODE	
Code (pages 4-9)	Description	Code	Description	Code	Description
11, 12A, 12, 22B, 22, 42	Internal Mix, Round	H	Hex Retaining Ring	3	303 Stainless
16, 26B, 30, 26, 29, 46	Internal Mix, Wide-Angle, Round	T	Teflon® Gasket & Washer	6	316 Stainless
13A, 13, N13, 14, 23B, N23, 23, 43	Internal Mix, Flat	C	Clean-out Assembly**	NP	Nickel-Plated Brass
1A, 1, 2A, 2, 4, 5	Siphon, Round	F	Flow Control (Shut-off)**	<p>Note: Although nickel-plated brass assembly appears to be all nickel when assembled, only the exterior surfaces of brass component are nickel-plated - see comparison below.</p>	
F1, F2C, F3B, F4B	Siphon, Flat	S	Shut-off and Clean-out (for standard bodies only)**		
E15B, E18B, E15A, E18A, E15, E18, E25B, E28A, E28A, E28A, E25, E28, E45B, E45A, E45	External, Flat	<p>Teflon® is a registered Trademark of The DuPont Corporation.</p> <p>* Use Option Codes only where applicable.</p> <p>** Shut-off and Clean-out options are not applicable to the Back-Connect body.</p>			
		<p>flow control</p>		<p>stainless</p>	
		<p>clean-out</p>		<p>nickel-plated</p>	
		<p>shut-off and clean-out</p>		<p>interior section not plated</p>	
				<p>Nickel-plated brass assembly</p>	

## Nozzles for Every Application

- **BEX has Thousands of Models of Spray Nozzles**
- **Available from Stock**
- **Industry's Best Delivery**

### What are you waiting for?

If you don't see what you're looking for, contact your BEX representative today.

U.S. Office:  
BEX, Inc.  
37709 Schoolcraft Rd.  
Livonia, MI 48150-1009  
U.S.A.  
(734) 464-8282 Phone  
(734) 464-1988 Fax  
sales@bex.com E-mail

In Europe:  
BEX Spritzduesen GmbH  
Diessemer Bruch 114E  
D-47805 Krefeld  
Germany  
(2151) 54 87 18 Phone  
(2151) 54 88 17 Fax  
eurosales@bex.com E-mail

In Canada:  
BEX Engineering Limited  
5115 Timberlea Blvd.  
Mississauga, ONT L4W 2S3  
Canada  
(905) 238-8920 Phone  
(905) 238-8955 Fax  
info@bex.com E-mail



**BEX**<sup>®</sup>  
**SPRAY NOZZLES**